

Inductance/Resistance Options: RF4: 4.00 Ohm, 0.36 mH
RF10: 12.00 Ohm, 1.00 mH

Air Gap: **Open Face:** ≤ .160", **Closed Face:** ≤ .130"

Frequency Range: ≤ 5 Hz to 6000 Hz

Temperature Ranges: 3T: -150° to 330° F (-101° to 165° C)
4HT: -350° to 400° F (-157° to 204° C)
5HT: -450° to 450° F (-270° to 232° C)

NOTE: Must be used with PA-10

3/8 M10 **Thread Size:** 3/8-24, M10x1.25
Length (L): 0.5" to 5" (13 to 130 mm)



1/2 **Thread Size:** 1/2-20
Length (L): 0.5" to 5" (13 to 130 mm)

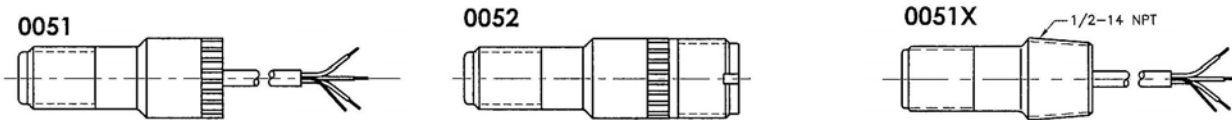

5/8 M16 **Thread Size:** 5/8-18 UNF, M16x1.5
Length (L): 0.5" to 10" (13 to 250 mm)

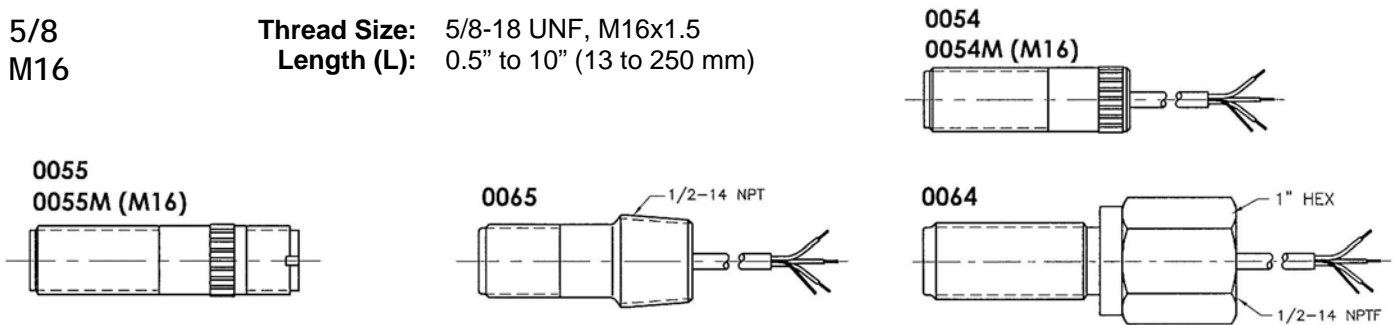

11/16 **Thread Size:** 11/16-24
Length (L): 0.5" to 3.5" (13 to 90 mm)

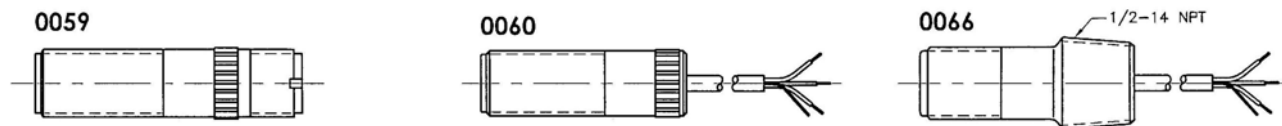

3/4 M18 **Thread Size:** 3/4-16, 3/4-20, M18x1.5
Length (L): 0.5" to 10" (13 to 250 mm)



Detailed specification sheets are available for each sensor listed; please contact Spectec for more information.